

Technical specification sheet

09 T 12 F + Trolley | Vari Pump

Specifications		
article number		101.003.032
model		09 T 12 F + Trolley
max. working pressure	psi	10443
short description		Vari Pump
capacity oil tank (effective)	oz	405.8
number of outputs		2
number of stages		1
first stage output / min.	oz	30.4
first stage pressure range	psi	0 - 10443
operator type		electric motor
engine		480 VAC - 60 Hz - 3 Ph
speed	rpm	3600
weight, ready for use	lb	264.6
dimensions (AxBxC)	in	54.7 x 28.7 x 27.6

Technical drawing dimensions		
dimension A	in	27.6
dimension B	in	28.7
dimension C	in	54.7

Standard supplied with	
•	Double acting valves (2x)
•	Pressure gauges (2x)
•	Couplers
•	Pump Trolley

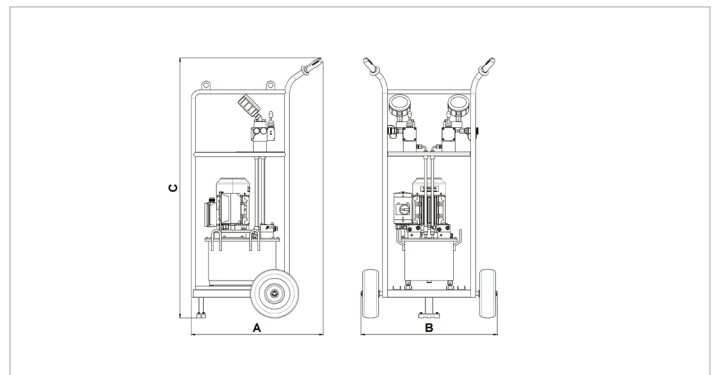

[holmatro.com](https://www.holmatro.com)

© Holmatro 2024-03-21

While the greatest care has been devoted to the content, it is possible that the information in this printed matter is incorrect or incomplete. Holmatro B.V. and its affiliated companies (hereafter: Holmatro) cannot be held liable in any way for the consequences of activities undertaken on the basis of this printed matter. Values can vary within the manufacturer measurements. If you have any doubts about the correctness or completeness of the information, you shall contact Holmatro (T +31 (0)162-751480). Nothing from this printed matter can be copied and/or made public in any way without the explicit authorisation of Holmatro.