

Holmatro

V-Strut





About **Holmatro**

For nearly half a century, Holmatro has been developing, producing and testing high-pressure hydraulic equipment for industrial, rescue, tactical and marine applications. Based on the needs of users, our products are known for their high quality and innovative technology. Holmatro sells and services these products through offices in various countries and an extensive dealer network.

When it comes to Holmatro rescue equipment, our highly experienced engineers translate innovative ideas into lighter, more powerful solutions for fire and rescue departments. The result is a full range of high-quality tools that enable you to work efficiently under pressure. It's safer, easier and quicker to save lives with Holmatro.

Holmatro products are made in the Netherlands and the USA at our state-of-the-art production facilities. Innovation, quality and service are at the heart of our company philosophy. Thanks to an extensive range of services including maintenance and training, our products last for years. That's why they're the tools of choice for rescue workers throughout the world. Once you use them, you'll use them for life.



Holmatro V-Strut

The V-strut is specially designed to stabilize any type of car quickly, easily and safely. Incorporating an integrated head, non-slip base plate and tensioning belt with a hook and ratchet mechanism, this all-in-one tool is ready for immediate use.

Although the V-Strut has a high shoring capacity of 16 kN, it weighs just 7.2 kg. This means it's easy to carry and handle. An auto-lock system with fine length adjustment enables you to set it up in no time. Simply pull it out to the required length and it locks automatically. This enables you to accurately position the V-Strut, whether the car is on its side or roof.

**You can
count on us,
for life**

Holmatro V-Strut: The lightweight tool for instant, safe stabilization

- Vehicle stabilization strut with integrated head, base plate and tensioning belt with hook and ratchet mechanism
- All-in-one solution, no loose parts that may get lost
- Ready for immediate use
- Unique auto-lock system
- Fast set-up in just 15 seconds

Unique auto-lock system



- Pulls out and locks automatically in one movement
- No separate operation required to lock the strut
- Locking holes over the full strut length at very small intervals
- Enables fine length adjustment for accurate positioning of the strut
- Quick, easy and safe

Squeeze and push mechanism



- To release the strut quickly and easily after use

Extremely lightweight



- Easy to carry
- Easy to work with
- Weighs just 7.2 kg

Serrated, multi-purpose head



- For optimal grip
- Suitable for use with all types of vehicles

Tensioning belt



- Tensioning belt with hook and ratchet mechanism
- For quick and easy attachment to the car
- Enables the rapid creation of a stable triangle





Snap hook



- For fast and easy detachment and reattachment



Reel for tensioning belt



- Prevents tangling of tensioning belt
- For compact storage



Base plate with non-slip profile



- For optimal grip on all surfaces
- Prevents the strut from slipping



Heat resistant cover



- Slideable, heat-resistant protection cover around tensioning belt
- Protects the belt against hot exhausts



Optional accessories ↓

- Sheet metal knife:
Suitable for quick and easy creation of a fixing point in the car's bonnet, roof or boot
- Holmatro PowerShore™ base support plate for use on soft soil, which prevents the strut from sinking into the ground



Technical data V-Strut ↓

article number	150.062.158
max. axial load (see F in drawing below)	16 kN
closed length	1080 mm
number of stroke steps	24
stroke step size	30 mm
total stroke	720 mm
extended length	1800 mm
weight	7.2 kg
dimensions (LxWxH)	1080 x 149 x 210 mm
length tensioning belt	5 m

Accessories V-Strut ↓

sheet metal knife	150.062.183
base support plate	150.011.519

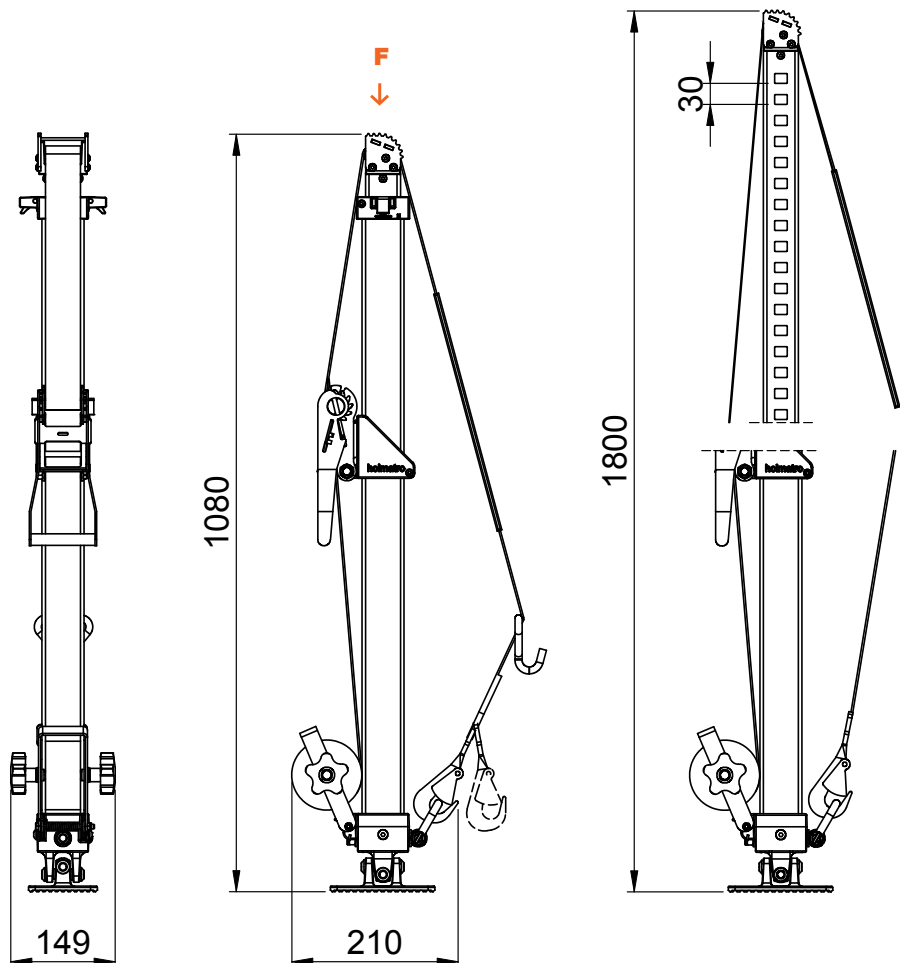



Holmatro Netherlands
Rescue equipment
Raamsdonksveer, The Netherlands
T +31 (0)162 58 92 00
E rescue@holmatro.com
Manufacturing, sales & service



Holmatro Group
World Headquarters
Raamsdonksveer, The Netherlands



Holmatro USA
Glen Burnie, MD, U.S.A.
Manufacturing, sales & service



Holmatro UK
Nottingham, UK
Sales & service



Holmatro China
Suzhou, Jiangsu Province, China
Sales & service



Holmatro Poland
Warsaw, Poland
Sales & service

www.holmatro.com

Disclaimer

While the greatest care has been devoted to the content, it is possible that the information in this printed matter is incorrect or incomplete. N.V. Holmatro and its affiliated companies (hereafter: Holmatro) cannot be held liable in any way for the consequences of activities undertaken based on this printed matter. If you have any doubts about the correctness or completeness of the information, you shall contact Holmatro (phone number: +31 (0)162-589200).

Nothing from this printed matter can be copied and/or made public in any way without the explicit authorisation of Holmatro.